

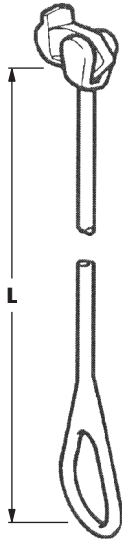

MODEL 5008-ELB-C

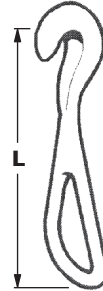

MODEL 5008-LB-4-310



MODEL 5008-A7D

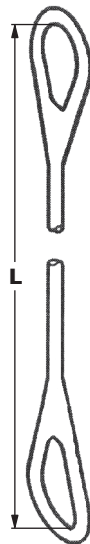

MODEL 5008-A7B-2

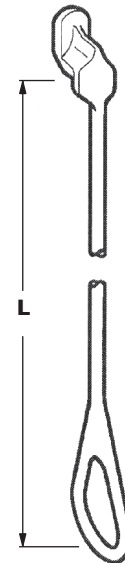

MODEL 5008-C6

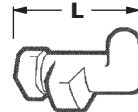

SPECIAL ORDER ONLY

SPECIAL ORDER ONLY

MODEL	MIN. B.S. (M. TON)	WEIGHT	
		L = 2,400 MM / 94-1/2"	L = 4,700 MM / 185-1/32"
5008-ELB-C-36	36	10.3 Kg / 22.7 LBS	17.1 Kg / 37.7 LBS
5008-ELB-C-50	50	12.1 Kg / 26.7 LBS	21.3 Kg / 46.9 LBS
5008-A7B-2-36	36	8.90 Kg / 19.6 LBS	15.8 Kg / 34.8 LBS
5008-A7D-50-1750	50	7.83 Kg / 17.25 LBS	L = 1,750 MM / 68-7/8"
5008-A7D-50-2550	50	11.34 Kg / 25 LBS	L = 2,550 MM / 100-13/32"
5008-LB-4-310	50	3.25 Kg / 7.16 LBS	L = 310 MM / 12-7/32"
5008-C6	36	3 Kg / 6.61 LBS	L = 125 MM / 4-29/32"

COUNTER PARTS: ISO CONTAINER CORNER
CASTING & TURNBUCKLES TYPE M5 & ELT

MATERIAL: HIGH-TENSILE STEEL
FINISH: HOT-DIP GALVANIZED (HDG)
CLASS APPROVED

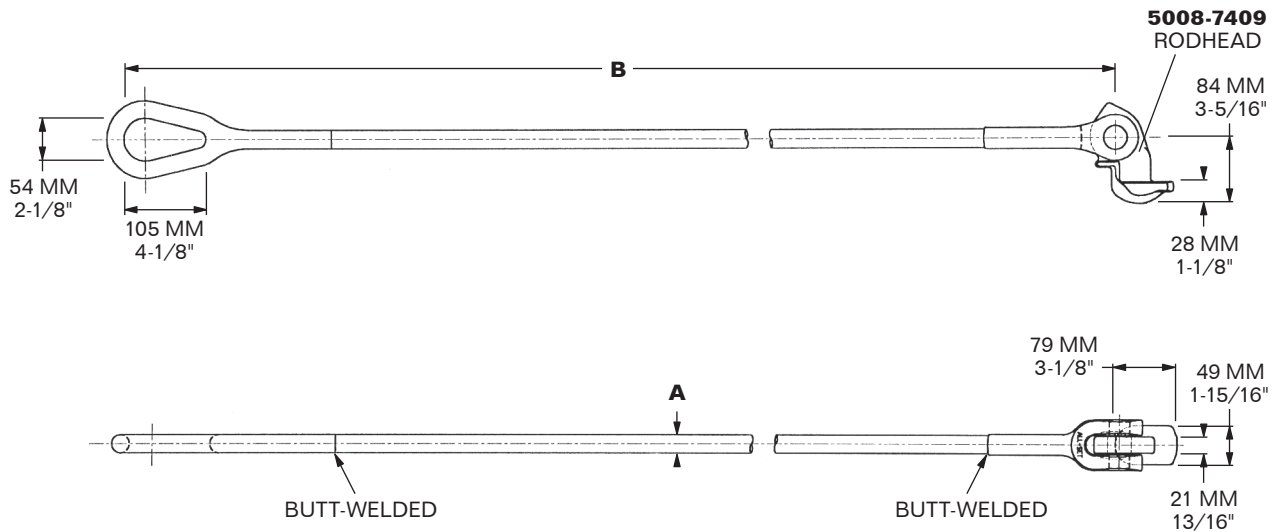

SPECIAL ORDER ONLY

	MODEL	MIN. B.S. (M. TON)	A	B	WEIGHT
SPECIAL ORDER ONLY	5008-ELB-C-36-2300	36	22 MM / 7/8"	2,300 MM / 90.6"	9.90 Kg / 21.8 LBS
SPECIAL ORDER ONLY	5008-ELB-C-36-2400	36	22 MM / 7/8"	2,400 MM / 94.5"	10.3 Kg / 22.8 LBS
SPECIAL ORDER ONLY	5008-ELB-C-36-4550	36	22 MM / 7/8"	4,550 MM / 179.1"	17.3 Kg / 38.1 LBS
	5008-ELB-C-36-4670	36	22 MM / 7/8"	4,670 MM / 183.9"	17.0 Kg / 37.6 LBS
SPECIAL ORDER ONLY	5008-ELB-C-36-4700	36	22 MM / 7/8"	4,700 MM / 185"	17.1 Kg / 37.7 LBS
	5008-ELB-C-42-4500	42	22 MM / 7/8"	4,500 MM / 177.2"	15.9 Kg / 35.0 LBS
	5008-LB-10/22-4500				
	5008-ELB-C-50-2150	50	25 MM / 1"	2,150 MM / 84.6"	11.0 Kg / 24.3 LBS
	5008-ELB-C-50-2200	50	25 MM / 1"	2,200 MM / 86.6"	10.9 Kg / 24.0 LBS
	5008-ELB-C-50-2260	50	25 MM / 1"	2,260 MM / 89"	11.6 Kg / 25.6 LBS
SPECIAL ORDER ONLY	5008-ELB-C-50-2300	50	25 MM / 1"	2,300 MM / 90.6"	11.6 Kg / 25.9 LBS
SPECIAL ORDER ONLY	5008-ELB-C-50-2330	50	25 MM / 1"	2,330 MM / 91.7"	13.2 Kg / 29.0 LBS
	5008-ELB-C-50-2400	50	25 MM / 1"	2,400 MM / 94.5"	14.0 Kg / 30.9 LBS
	5008-ELB-C-50-4700	50	25 MM / 1"	4,700 MM / 185"	21.0 Kg / 46.3 LBS
	5008-LB-10-4500	50	25 MM / 1"	4,500 MM / 177.2"	19.96 Kg / 44 LBS
SPECIAL ORDER ONLY	5008-LB-10-5029	50	25 MM / 1"	5,029 MM / 198"	23.3 Kg / 51.36 LBS

MATERIAL: STEEL
FINISH: HOT-DIP GALVANIZED (HDG)
CLASS APPROVED

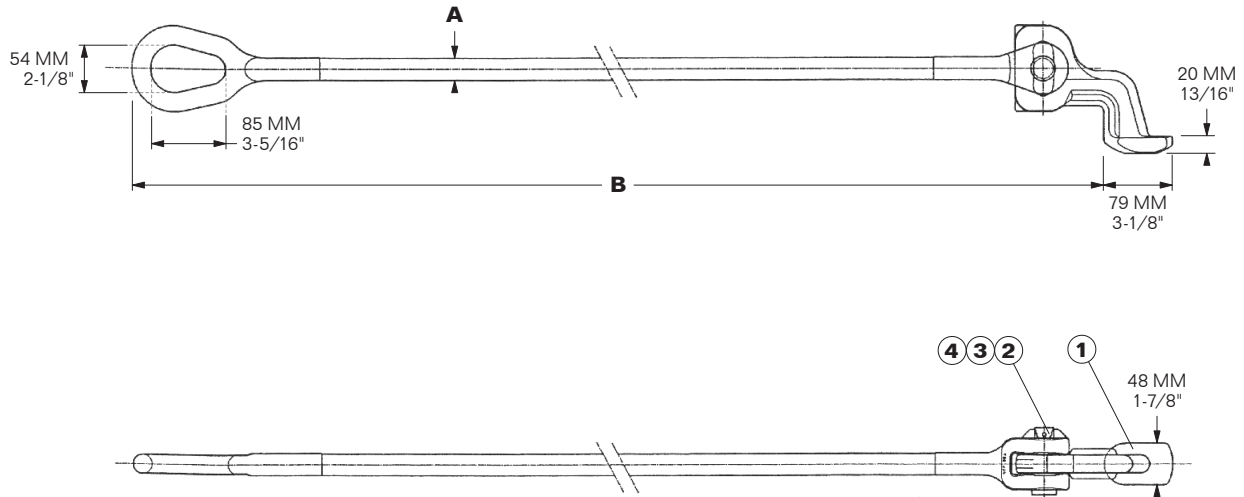

SPECIAL ORDER ONLY

MODEL	APM #	A	B	WEIGHT
5008-LB-2100-00	308044	25 MM / 1"	2,100 MM / 82-11/16"	11.7 Kg / 25.8 LBS
5008-LB-2505-00	308046	25 MM / 1"	2,505 MM / 98-5/8"	13 Kg / 28.8 LBS
5008-LB-2690-00	312852	25 MM / 1"	2,690 MM / 105-7/8"	13.9 Kg / 30.6 LBS
5008-LB-3000-00	308048	25 MM / 1"	3,000 MM / 118-1/8"	15.1 Kg / 33.3 LBS

SPECIAL ORDER ONLY

SPECIAL ORDER ONLY

ITEM	QTY.	MODEL	APM #	DESCRIPTION	WEIGHT
1	1	5008-APM-2100-00/1	308142	RODHEAD, HDG	2.1 Kg / 4.6 LBS
2	1	5008-APM-2100-00/5	308144	PIN, HDG	0.25 Kg / 0.55 LBS
3	1	5008-APM-2100-00/6	308145/1	SPRING PIN 6 x 28 MM, SS	0.07 Kg / 0.15 LBS
4	1	5008-APM-2100-00/7	308145/2	SPRING PIN 3.5 x 28 MM, SS	0.02 Kg / 0.05 LBS

NOTE: THE 3.5 MM SPRING PIN FITS INSIDE THE 6 MM SPRING PIN.

MIN. B.L.: 48 M. TON

MATERIAL: STEEL
FINISH: HOT-DIP GALVANIZED (HDG)



MODEL 5008-A7B-2

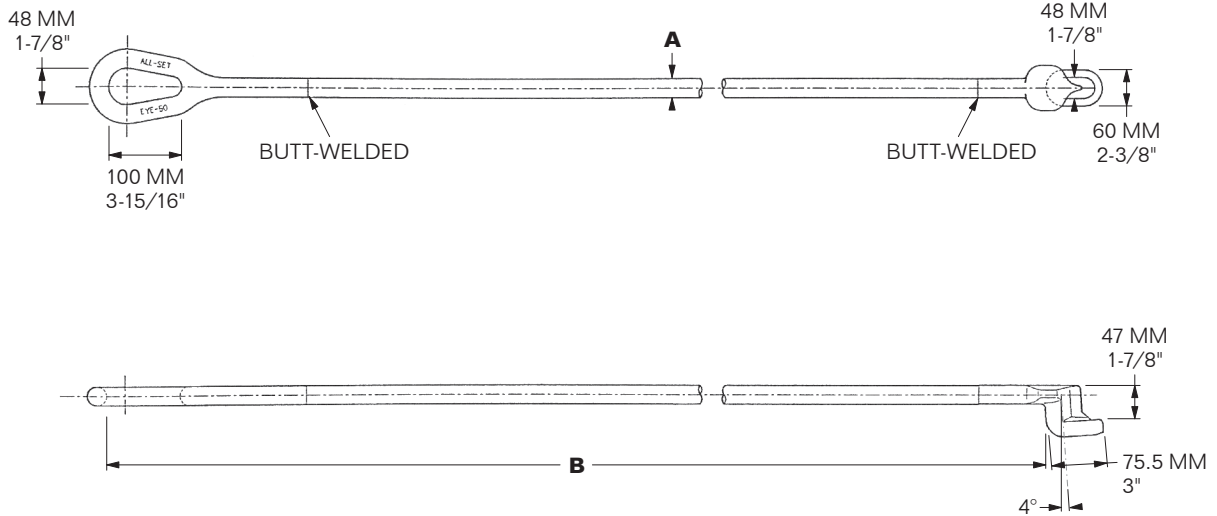

	MODEL	MIN. B.L. (M. Ton)	A	B	WEIGHT
SPECIAL ORDER ONLY	5008-A7B-2-36-2130	36	22 MM / 7/8"	2,130 MM / 83.9"	8.8 Kg / 19.4 LBS
SPECIAL ORDER ONLY	5008-A7B-2-36-2200	36	22 MM / 7/8"	2,200 MM / 86.6"	9 Kg / 19.8 LBS
SPECIAL ORDER ONLY	5008-A7B-2-36-4570	36	22 MM / 7/8"	4,570 MM / 180"	14.9 Kg / 33 LBS
SPECIAL ORDER ONLY	5008-A7B-2-36-4600	36	22 MM / 7/8"	4,600 MM / 181.1"	15.9 Kg / 35 LBS
SPECIAL ORDER ONLY	5008-A7B-2-36-4750	36	22 MM / 7/8"	4,750 MM / 187"	15.9 Kg / 35 LBS

MATERIAL: STEEL
FINISH: HOT-DIP GALVANIZED (HDG)
CLASS APPROVED

MODEL 5008-APM-2100-00/5

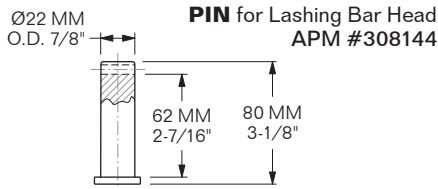

WEIGHT: 0.25 Kg / 0.55 LBS

MODEL 5008-APM-2100-00/6-7

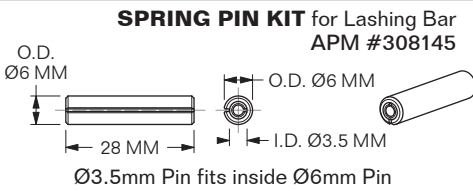

WEIGHT: 0.09 Kg / 0.2 LBS

MODEL 5008-APM-2100-00/1

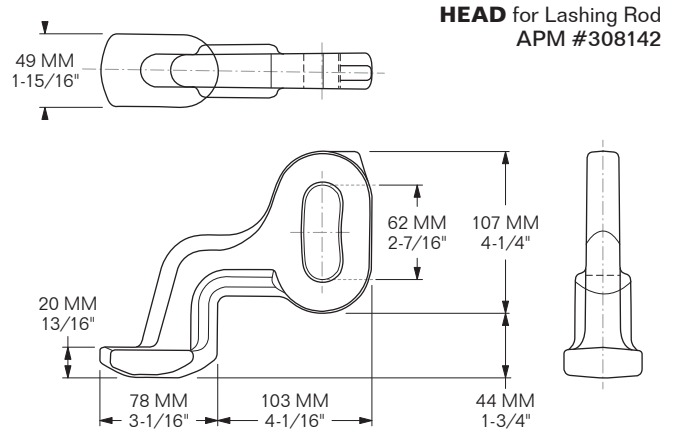

MATERIAL: FORGED STEEL
FINISH: HOT-DIP GALVANIZED (HDG)
WEIGHT: 2.09 Kg / 4.6 LBS

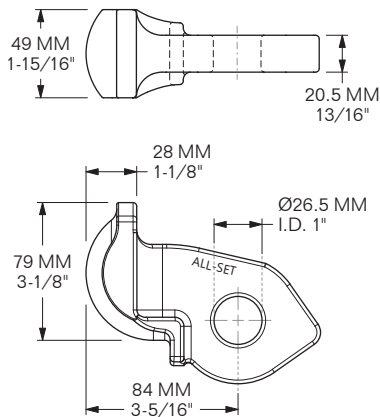

MODEL 5008-7409-1-1071837

HINGED ROD HEAD for Lashing Rods
ELT, FLX, LB-10, LB-11, LB-31

WORKS WITH: CLEVIS BOLT KIT
5008-7409-2-1071836-KIT *
MATERIAL: FORGED STEEL
FINISH: HOT-DIP GALVANIZED (HDG)
WEIGHT: 1.26 Kg / 2.78 LBS

* MOUNTING HARDWARE SOLD SEPARATELY
(see catalog pg. 5008-6).

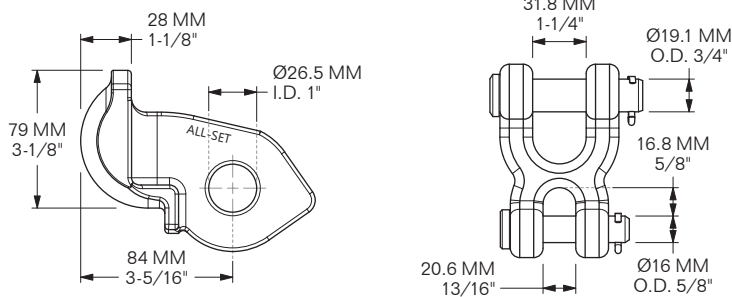
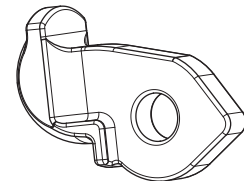

MODEL 5008-7409-KIT

Hinged Lashing Rod Head
5008-7409-1-1071837

Double Clevis Link
2901-1/2DCLGR70

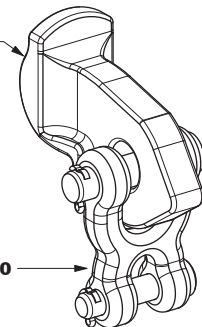

MATERIAL: FORGED STEEL **FINISH:** HOT-DIP GALVANIZED (HDG)
WEIGHT: 2.02 Kg / 4.46 LBS **MBS:** 36,800 LBS / 16.6 M. TON



FASTENING HARDWARE for HINGED LASHING ROD HEADS

WORKS WITH: HINGED ROD HEAD 5008-7409-2-1071837
KIT WEIGHT: 0.66 LBS / 0.3 Kg

MODEL 5008-7409-2-1071836-KIT

CLEVIS BOLT KIT for Hinged Lashing Rod Head on LB-10, LB-11, LB-15 & LB-31 Lashing Bars

This kit contains 1 ea. of the following components:

(Components can also be purchased separately)

5008-7409-2-1071836

CLEVIS BOLT w/
 Ø23.5mm Body & M16 Thread

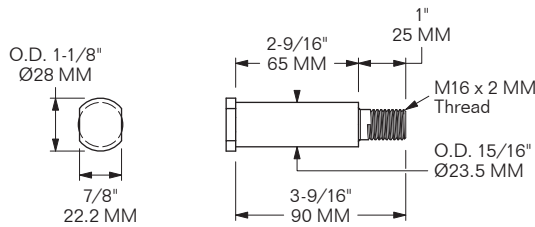

MINIMUM BREAK STRENGTH: 50 M. TON

SUB FOR: MACGREGOR 1071836
MATERIAL: HIGH-TENSILE STEEL
FINISH: HOT-DIP GALVANIZED
WEIGHT: 0.57 LBS / 0.26 Kg

5008-7409-3

HEX NUT
 w/ Nylon Insert,
 M16 x 2mm Thread

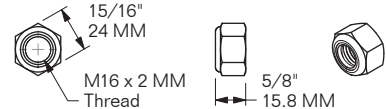

SUB FOR: MACGREGOR 1009487
MATERIAL: STAINLESS STEEL
FINISH: SELF-COLOR
WEIGHT: 0.07 LBS / 0.03 Kg

5008-7409-4

FLAT WASHER,
 17mm x 41mm x 7mm

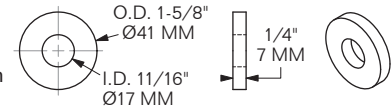

SUB FOR: MACGREGOR 1009601
MATERIAL: CARBON STEEL
FINISH: HOT-DIP GALVANIZED
WEIGHT: 0.02 LBS / 0.01 Kg

ALTERNATE BOLTING HARDWARE for Hinged Lashing Rod Heads

For **BREAK STRENGTH** up to **50 M. TON**, use:

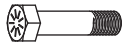

5008-4929-G9
HEX BOLT
 7/8"-9 x 3-1/2", Grade 9,
 Geomet 720 coating



5008-4719
HEX NUT
 7/8" Self-locking,
 Crimped End



5008-4720-HDG
FLAT WASHER
SPECIAL ORDER ONLY
 7/8", HDG

For **BREAK STRENGTH** up to **42 M. TON**, use:

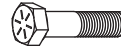

5008-4717-G8 —OR—
HEX BOLT
 7/8"-9 x 3-1/2", Grade 8,
 Zinc-plated

5008-4718-G8
HEX BOLT
SPECIAL ORDER ONLY
 7/8"-9 x 4", Grade 8,
 Zinc-plated

MODEL 5008-C6

**Penguin Hook,
Short**

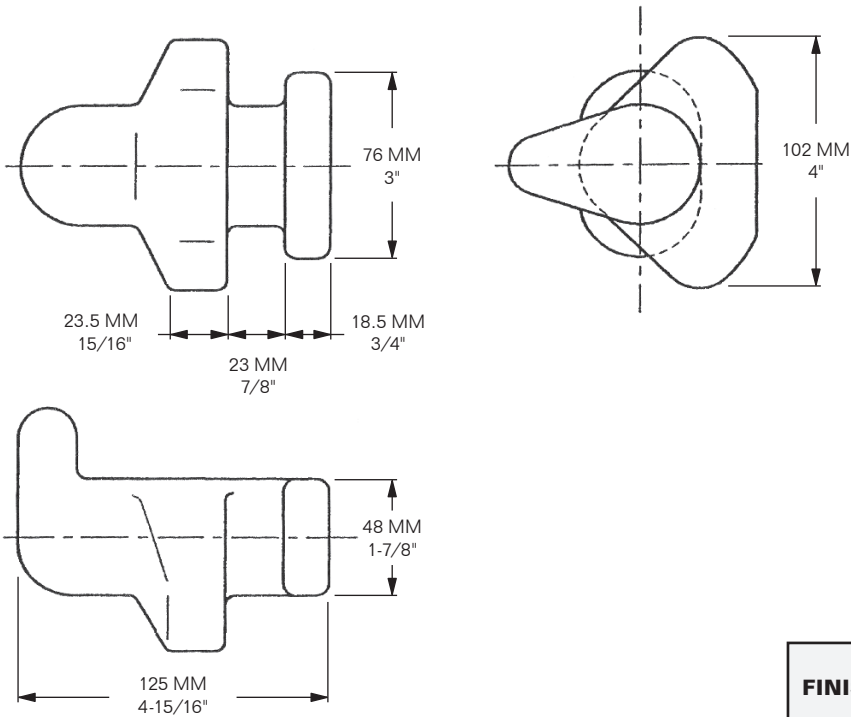

MIN. B.S.: 36 M. TON

MATERIAL: STEEL
FINISH: HOT-DIP GALVANIZED (HDG)
WEIGHT: 3 Kg / 6.61 LBS

SPECIAL ORDER ONLY MODEL 5008-2738

**SECURING EYE PAD, FITS INTO
ISO CORNER CASTINGS**

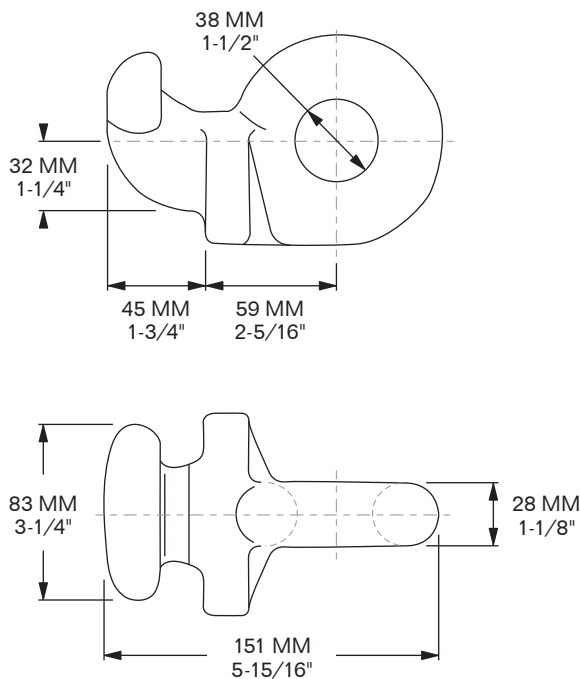

MIN. B.S.: 36 M. TON

MATERIAL: STEEL
FINISH: HOT-DIP GALVANIZED (HDG)
WEIGHT: 2.36 Kg / 5.2 LBS

MODEL 5008-LB-4-310
FULLY FORGED

MIN. B.L. TENSION: 50 M. TON

MATERIAL: STEEL
FINISH: HOT-DIP GALVANIZED (HDG)
WEIGHT: 3.25 Kg / 7.2 LBS

MODEL 5008-A7F-50-460/18
MODEL 5008-A7F-50-610/24
for High-Cube Containers,
Butt-welded

MIN. B.L. TENSION: 50 M. TON

MATERIAL: STEEL
FINISH: HOT-DIP GALVANIZED (HDG)

MODEL	A	WEIGHT
5008-A7F-50-460/18	457 MM / 18"	3.8 Kg / 8.4 LBS
5008-A7F-50-610/24	610 MM / 24"	4.4 Kg / 9.7 LBS